

# Sanicubic 1 VX

## Grey water, black water

Sanicubic 1 VX is a lifting station with one vortex pump. It is designed for lifting waste water from houses or small commercial premises. Sanicubic 1 VX has direct and safe access to the motor and level sensors. The lifting station comes with a classic control box and a wired alarm.



### PERFORMANCE

- Total head: 13 m
- Max. flow rate: 40 m<sup>3</sup>/h

### PRODUCT BENEFITS

- Floor standing for easy installation
- Easy access for maintenance
- 3 inlets
- Vortex technology
- Direct and safe access to the motor
- Comes with classic control box
- Comes with wired alarm



### DELIVERED AS STANDARD

Classic control box

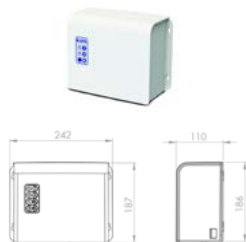



Remote wired audible and visual alarm unit (5m)

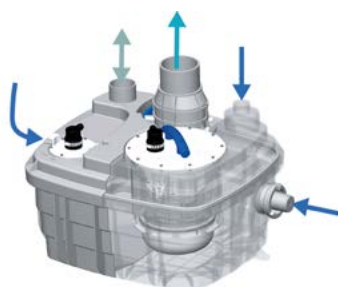

### CONNECTIONS



-  External inlet diameter: 40/50/100/110/125 mm
-  External discharge diameter: 90/110 mm
-  External ventilation diameter: 75 mm



vortex

Visit [Plumb2u](https://www.plumb2u.com)

See product

## DIMENSIONS

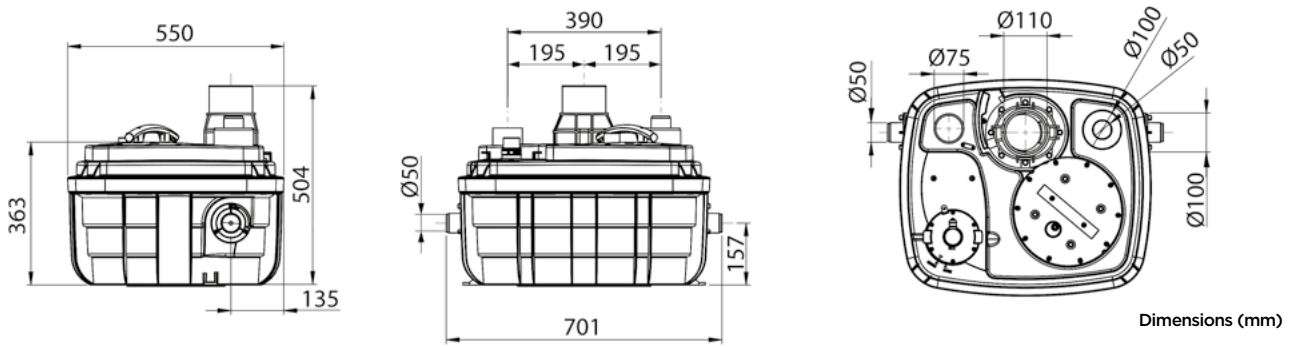

## CURVE

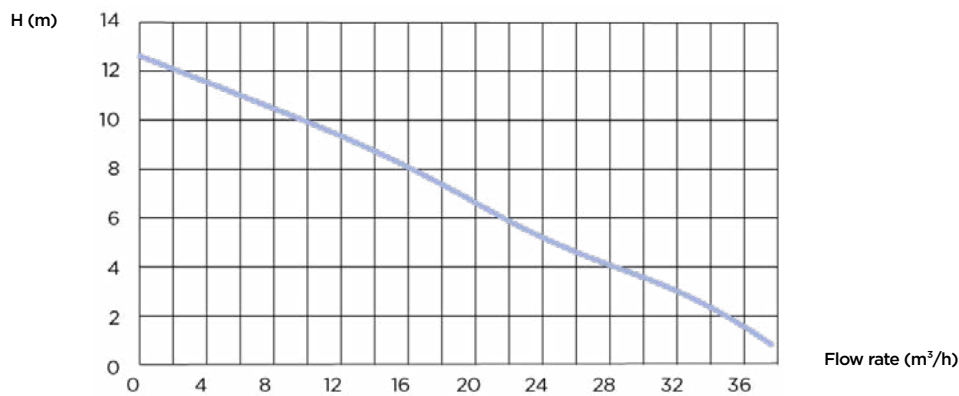

| Sanicubic 1 VX                                |                   |
|---|-------------------|
| Type of control box                           | Classic           |
| <b>Material</b>                               |                   |
| Tank  | PP GF             |
| Pump housing                                  | PA 12 GF          |
| Motor housing                                 | PA 12 GF          |
| Impeller                                      | PPO GF            |
| <b>Electrical features</b>                    |                   |
| Voltage (V)                                   | 230               |
| Power consumption P1 (W)                      | 2000              |
| Power output P2 (W)                           | 1400              |
| Mode of operation                             | S3 15%            |
| IP rating                                     | IP68              |
| <b>Hydraulics</b>                             |                   |
| Total head (m)                                | 13                |
| Max. flow rate ( $m^3/h$ )                    | 40                |
| External inlet diameter (mm)                  | 40/50/100/110/125 |
| External discharge diameter (mm)              | 90/110            |
| External ventilation diameter (mm)            | 75                |
| Total volume (L)                              | 60                |
| Useable volume (L)                            | 21                |
| ON level /OFF level (mm)                      | 165/95            |
| Alarm level (mm)                              | 235               |
| Particle size (mm)                            | 50                |
| Max. temperature of the pumped liquid (5 min) | 70°C              |
| Type of impeller                              | vortex            |
| Type of activation                            | pneumatic         |
| <b>Identification and logistics</b>           |                   |
| Gross weight (kg)                             | 30                |
| Barcode                                       | 3308815077611     |
| Product code                                  | 30005             |

Visit [Plumb2u](https://www.plumb2u.com)

See product