

# Emma Gas Spring Monitor Arm - Double

## DA-DLB851D2

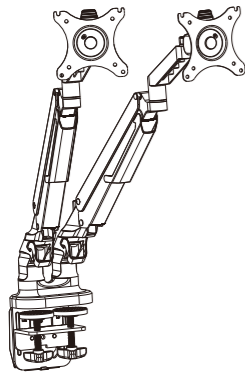

**M 4x12mm A(8PCS)**    **M 5x12mm B(8PCS)**    **M 6x12mm C(3PCS)**    **ø 6.5Xø 13X1.8 D(16PCS)**    **4x4 Allen Key E(1PC)**    **5x5 Allen Key F(1PC)**

- Support arm (1PC)
- Base Mounting Plate (1PC)
- Protection pad (2PCS)
- Protection pad (1PC)
- Plastic cable cover (1PC)
- Perforated plate (1PC)
- Long screw (1PC)
- Protection pad (1PC)
- Pressure plate (1PC)
- Knob nut (1PC)
- Mount Plate (2PCS)
- Clip (2PCS)



### STEP 2-B

Option2: Grommet



- Notice: Keep the counterbore side down
- Available hole size: 8.5-70mm
- For desk thickness: 25-100mm
- Tighten

### STEP 1

The Preparation Before Monitor Installation

1. Make sure there are VESA holes 100x100mm or 75x75mm in the monitor. If not, the mount couldn't be installed.
2. Remove the original fixed base of monitor. Be careful not to scratch the screen.

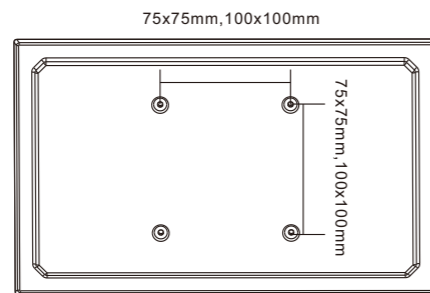

### STEP 3

Connect the plate and monitor

- Use washer if needed (D)
- Use the allen key (F) to tighten the screw

### STEP 2-A

Option1: Clamp

select proper available hole according to thickness of desk

Caution

4x4mm

- For desk thickness: 20-60mm
- Tighten

### STEP 4

Install the monitor to the arm

- Connection plate
- Lock

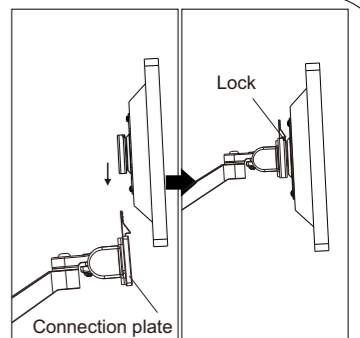

Hang the monitor on the plate from top to bottom and ensure it be tightened

## STEP 5

Adjust the monitor

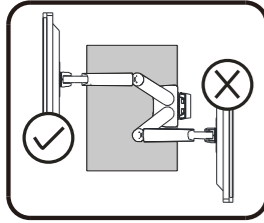

Caution: Please do not turn the monitor to the back to ensure the safe of possession and body

▲ Factory setting: 5-7KG

Adjust the monitor's height after installing. If the monitor cannot stop at any height, pls use the supplied 5x5 allen key to adjust the screw on the arm. To make the mount and monitor's weight equal and it can stop at any height, pls adjust the screw in "-" direction when the monitor up and "+" direction when it down.

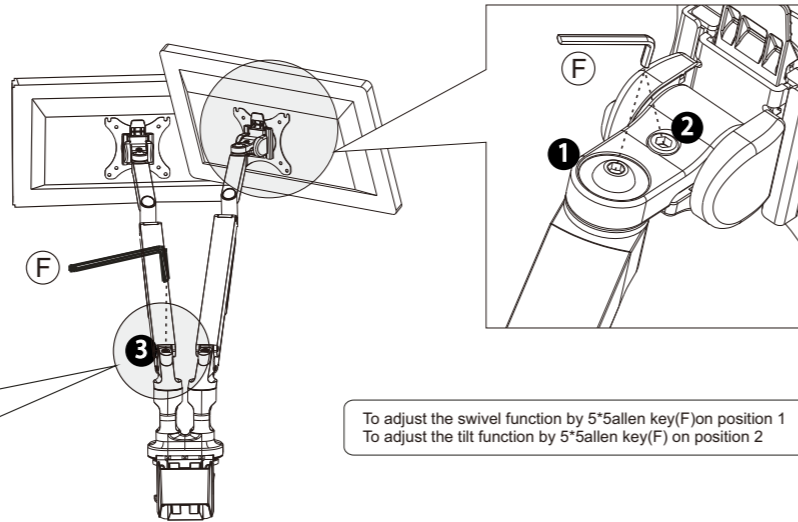

To adjust the swivel function by 5\*5allen key(F)on position 1  
To adjust the tilt function by 5\*5allen key(F)on position 2

## Specification

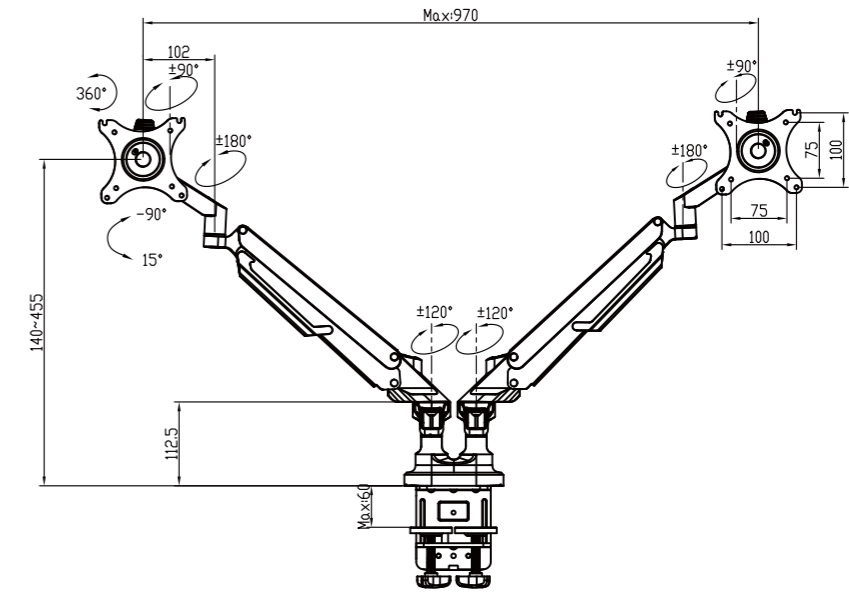

## STEP 6

Adjust the Rotation Arm

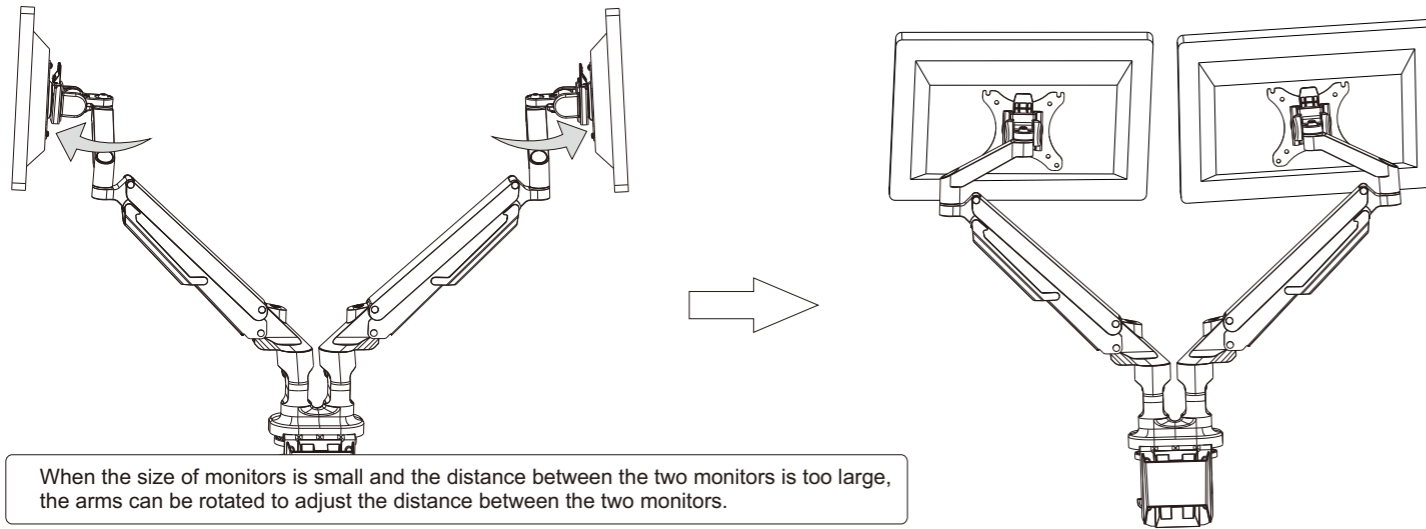

When the size of monitors is small and the distance between the two monitors is too large, the arms can be rotated to adjust the distance between the two monitors.

## Cable Management

1. Take off cable management and put cable management back to cover cables once finishing the management

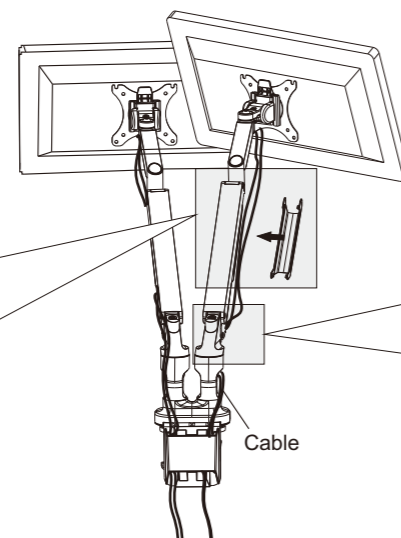
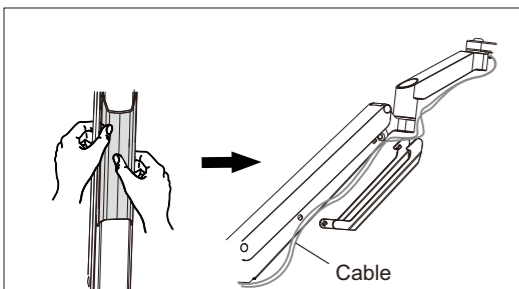

2. Buckle the clips (12) after organizing the cables.

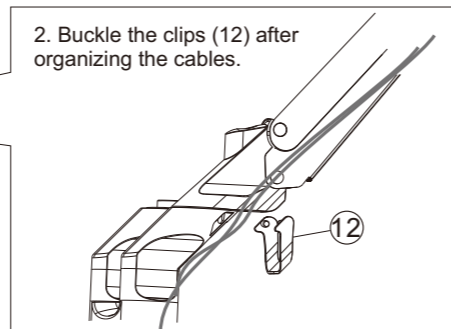

## CAUTION

This product contains small items that could be a choking hazard if swallowed. Keep these items away from young children.

- Make Sure these instructions are read and completely understood before attempting installation. If you are unsure of any part of this installation, please contact a professional installer for assistance.
- The desk or mounting surface must be capable of supporting the combined weight of the mount and the display, otherwise the structure must be reinforced.
- Safety gear and proper tools must be used. A minimum of two people are required for this installation. Failure to use safety gear can result in property damage, serious injury or death.
- please check joint parts every two months, making sure the screws are loosened or not.

This product was designed to be installed on desk. Before installing, make sure the mount will support the combined load of the equipment and hardware. Never exceed the maximum load capacity 9 KG, or else it may result in product failure or personal injury.

Note: this product is intended for indoor use only. Use of this product outdoors could lead to product failure or personal injury.

**Warning:** This product contains high pressure gas spring parts, please do not put it into fire, high temperature, or disassemble it, which will lead to unexpected personal injury. The obsolete products can be sent back to the manufacturer or handed over to professional institutions.

To ensure the sealing performance of the gas spring, it is suggested to have complete adjustment to the upper arm (with spring) one time or several times every month.